

Sourcing in SE ASIA: The SAFSA Model

Michael Blakeley
Nathan Associates Inc.
VALUE PROJECT
July 26, 2011

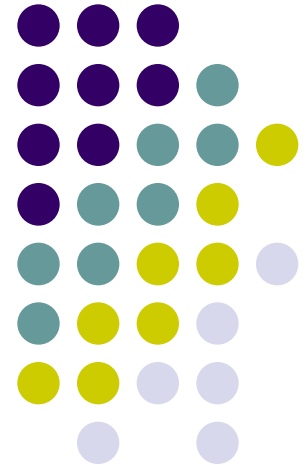

What is SAFSA?

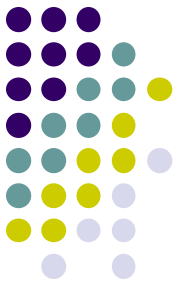

An alliance of ASEAN's top textile mills and garment factories offering a "full package" source of quality textile and apparel

SAFSA Background

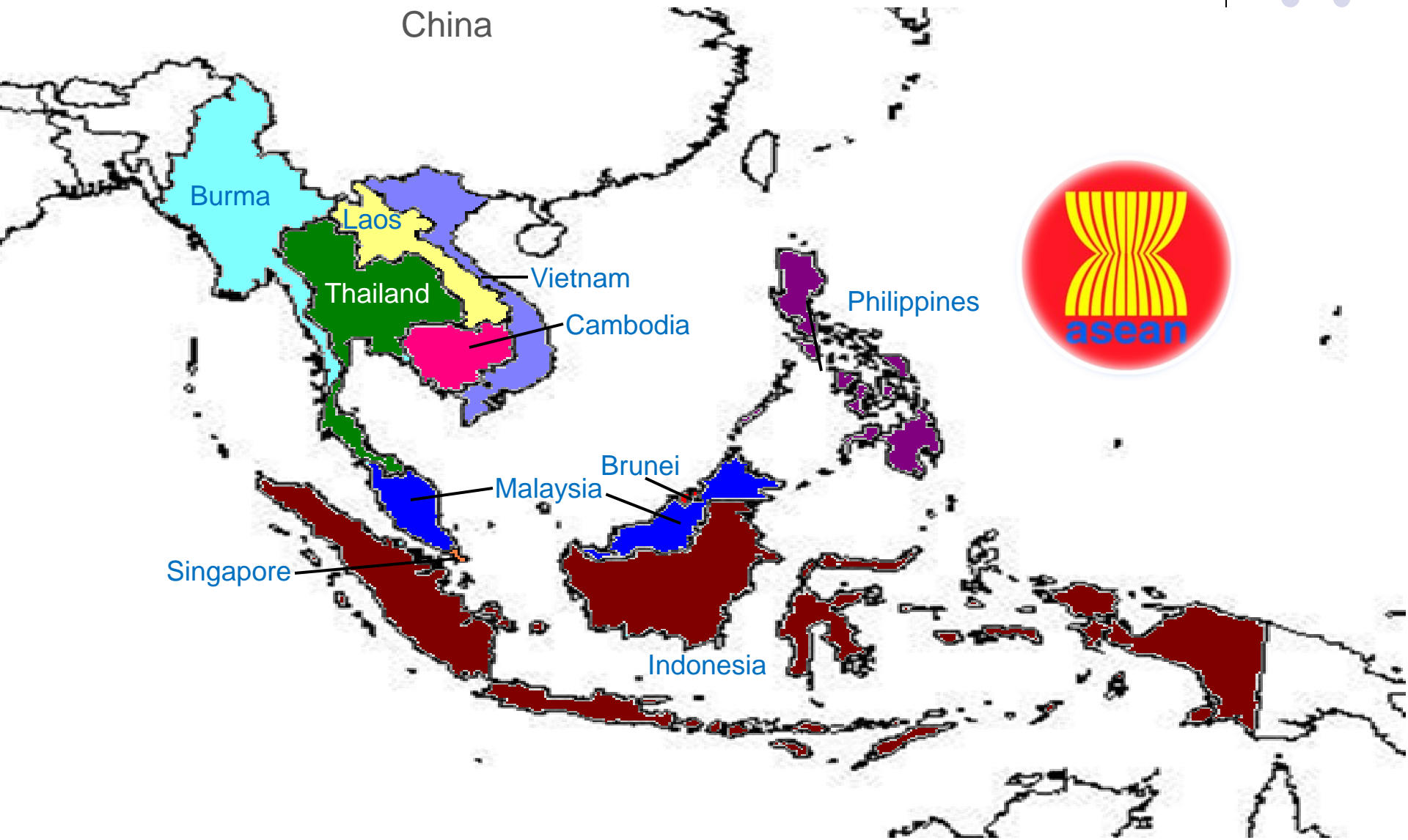
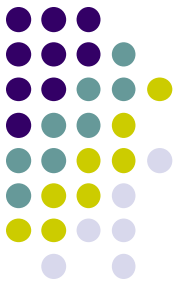

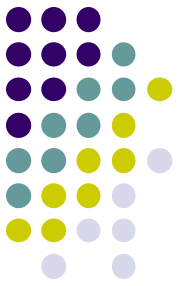

“Blueprint”

- Create a single market and production base



Free flow of goods, services and labor



Accelerate liberalization and integration of sectors



Textiles and apparel 1 of 12 sectors

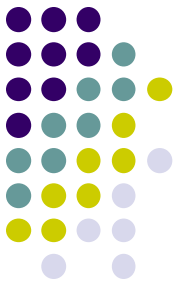

Sector Interests

- Competing with China and others
- Free Trade *Arrangements*
- Responding to dynamics & burdens of the market
 - *Disaggregated services*
 - *Time/Speed to market*

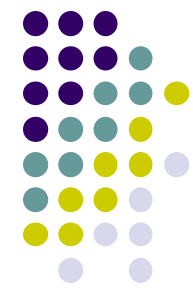

A Solution was Needed

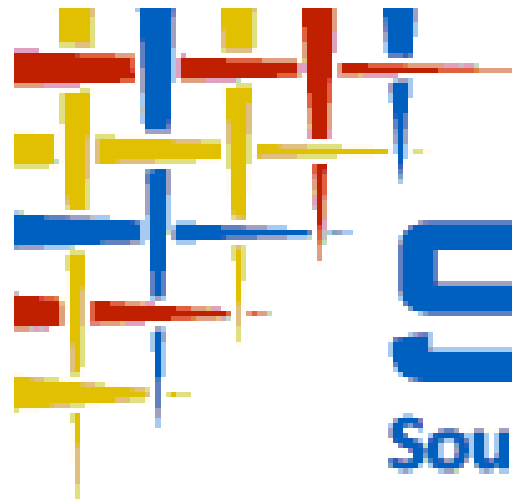

SAFSA
Source ASEAN Full Service Alliance

A complicated process

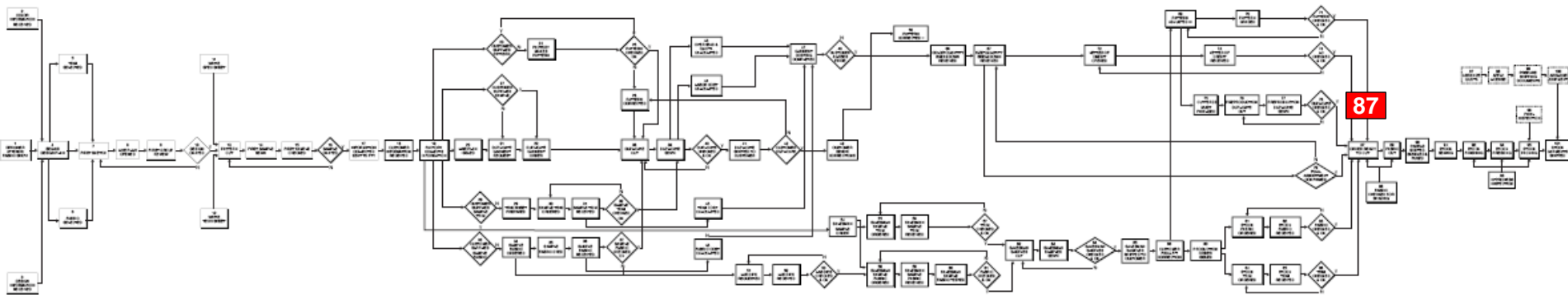
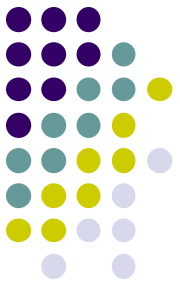

Design

Sample

Salesman
Sample

Order
Confirm

CMT+
Delivery

94 %

6 %



Building Block: “VVF’s”

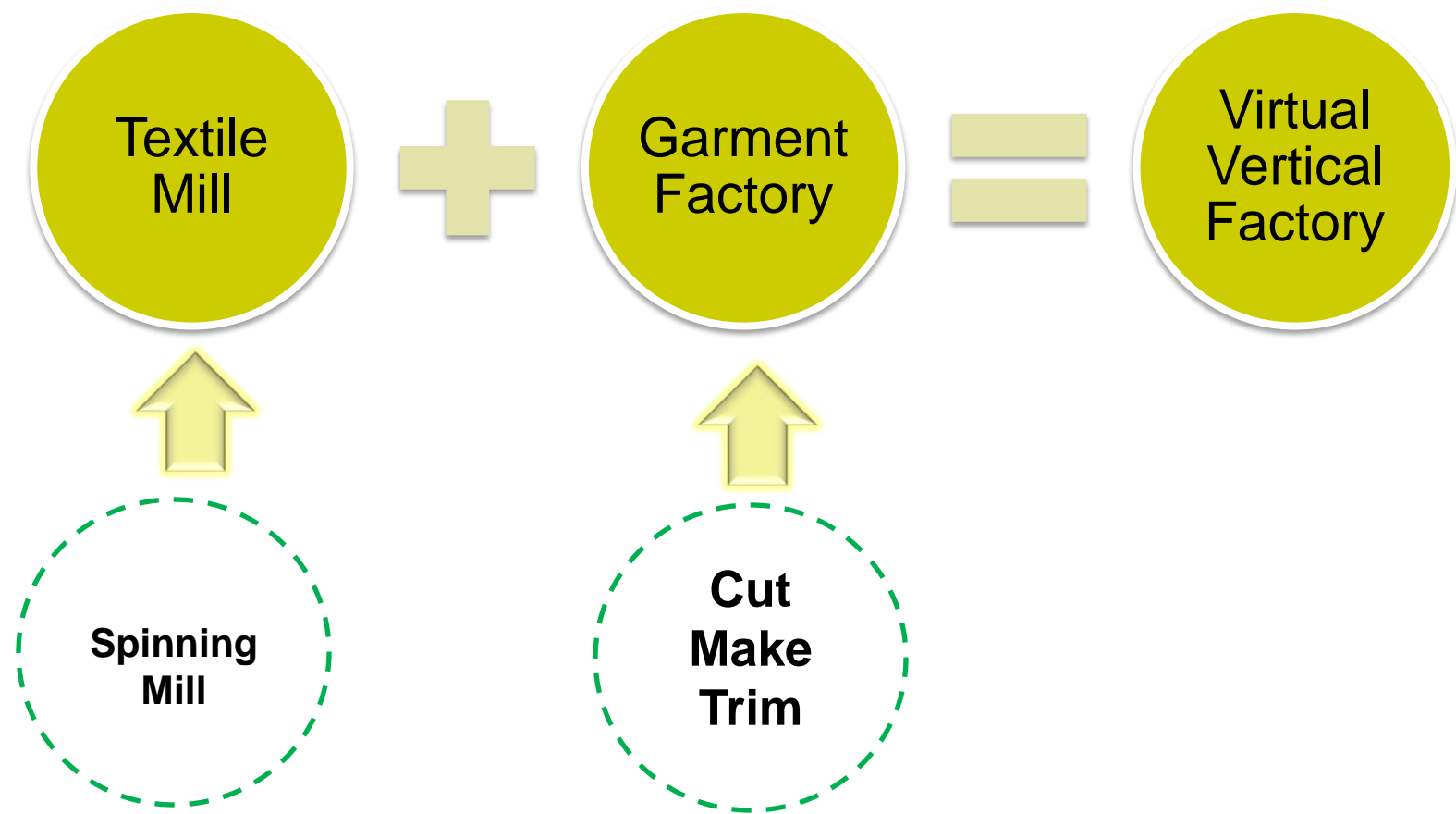

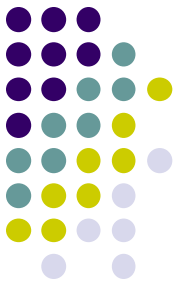

3 Forms of VVF

- Cross border
- In country
- Spaghetti bowl

Snapshot of Current VVF

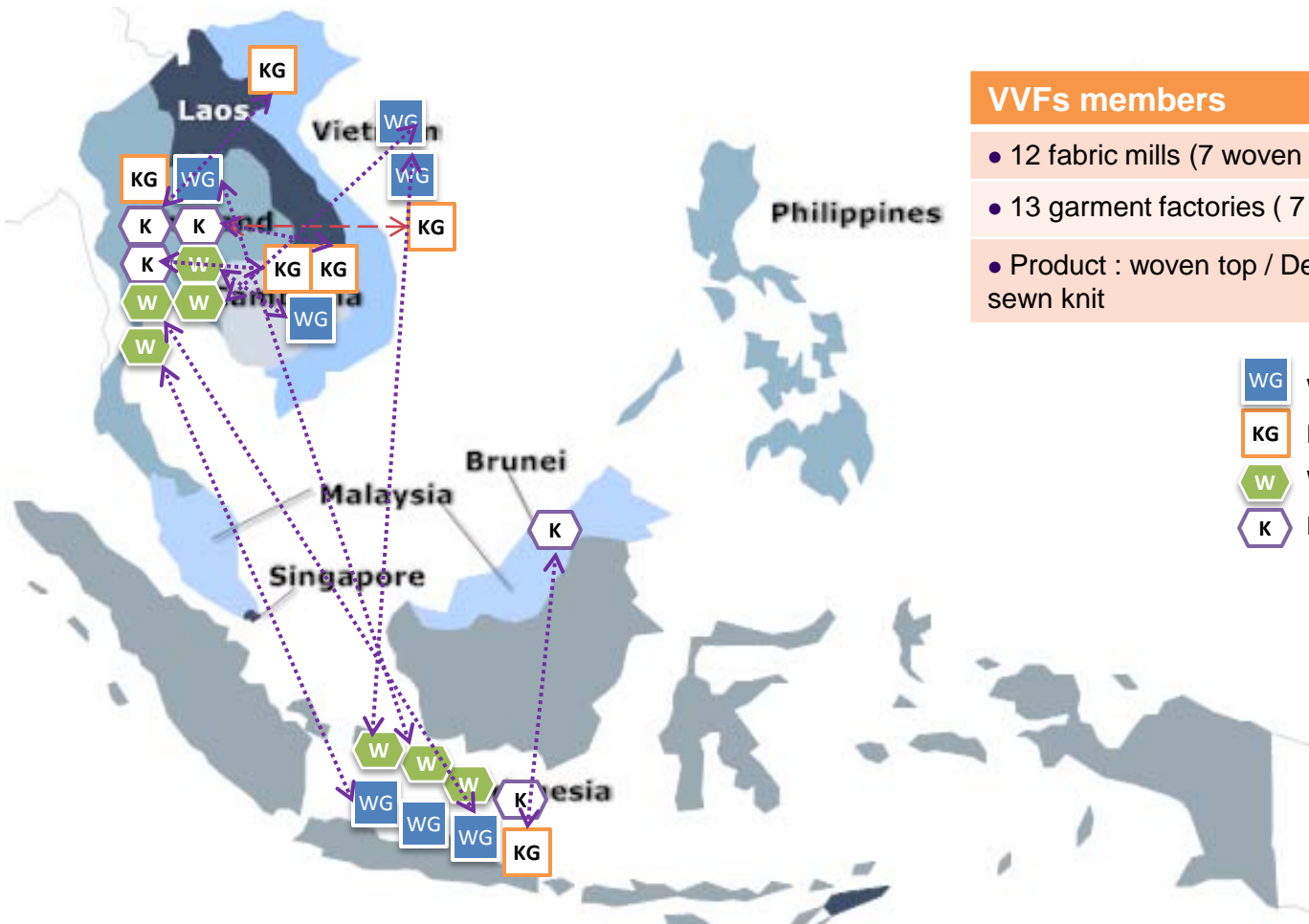
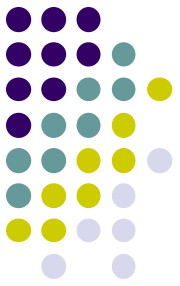

- ### VVFs members
- 12 fabric mills (7 woven and 5 knit)
 - 13 garment factories (7 woven and 6 knit)
 - Product : woven top / Denim / cut-make-sewn knit

-  Woven Garment Factory
-  Knit Garment factory
-  Woven Textile Mill
-  Knit Textile Mill



Quality Control

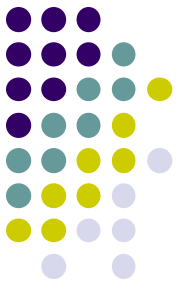

SAFSA code of conduct

- One time audit for VVF applicant, then follows customer's standards practices or if requested by SAFSA.
- Exemption for factories holding valid certificate of
 - SA8000
 - Wrap (Level A and B)
 - BSCI audit (a good report result)



SGS



SAFSA Quality Service audit

- Separate audit checklist between mill and factory
- SGS's checklist is reviewing by Werner International
- The audit will be undertaken at least once every two years

The Other Half of the Equation

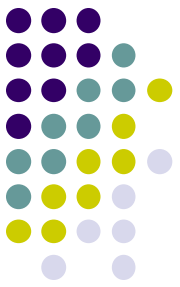

AVON



POLO
RALPH LAUREN

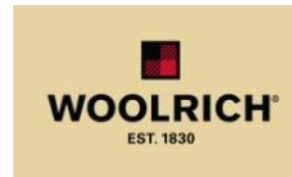

DEBENHAMS

MARKS &
SPENCER

MaxMara

MANGO

SAFSA Customer Requirements

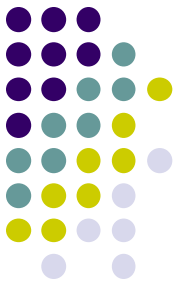

- No fee
- Commitment to partnership with VVF
- Membership approval
- Participation in annual Global Forum



B2B Feature: The Global Forum

Establish direct business relationships between VVFs and customers

Signing Memoranda of Understanding



Direct relationship with buyers



Business Matching

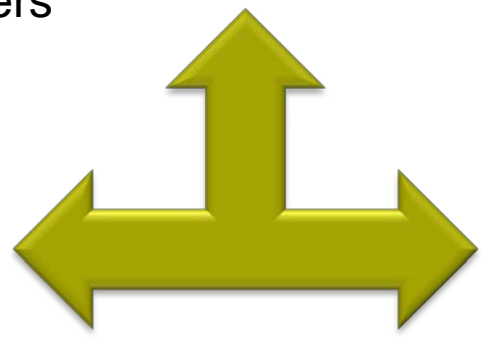

How can you join?

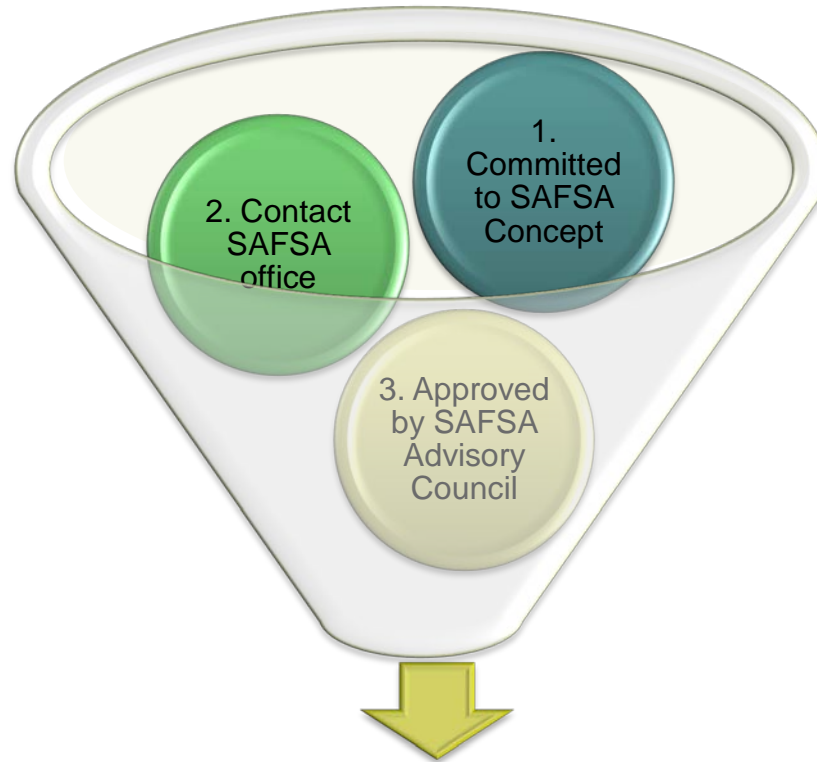
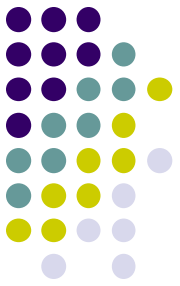

SAFSA customers

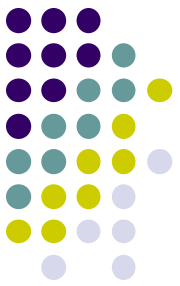

Timeline & Key Dates



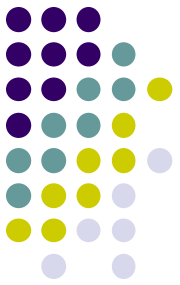

Inside the Numbers

- -0.75% vs. 16.10%
- 2015
- 0

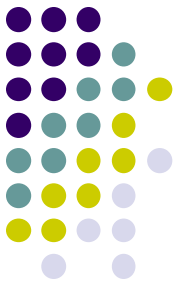

Website: www.sourceasean.com/safsa

Email: safsa@sourceasean.com

mblakeley@nathaninc.com